



Itemiser[®] 5X

Rapiscan[®] Systems



Selmatec AS is an ISO9001: 2015 approved company and an Environmental Certified company (Miljøfyrtårn)



DATASHEET



The Itemiser 5X uses optimized detection libraries and advanced software algorithms, making it the ideal solution for detecting trace amounts of explosive and narcotic threats. The non-radioactive ionization source eliminates the need for annual wipe tests and licensing, as well as reduces shipping challenges.

This portable, ergonomic desktop design features automated internal calibration to help decrease consumables usage, boost availability rates, and increase detection probability.

NEW SUBSYSTEMS FOR GREATER RELIABILITY & ADVANCED SOFTWARE ALGORITHMS

FASTER CLEAR DOWNS

NEW DESORBER DESIGN MAKES FOR MORE EFFICIENT SAMPLE INTRODUCTION

NEW SAMPLE WAND WITH GREATER ERGONOMICS AND SAMPLE INTRODUCTION

REMOTE MONITORING VIA REMOTE CONNECT CONSOLE

US
TSA ACSTL
APPROVED

CHINA
CAAC
CERTIFIED

RELIABLE

Maintains a low, stable humidity level in the detector, allowing for consistent and reliable detection results.

High-capacity internal solid-state hard drive for reliable data storage.

Includes preventative maintenance reminders (optional).

Advanced diagnostics to ensure maximum availability and performance.

New algorithms supporting increased detection performance.

PORTABILITY

Lightweight (28.65 lb/12.99 kg) with built-in handle for easy transport.

Internal, one-hour battery allows instrument relocation without shut off, eliminating warmup time.

INCREASED USER EXPERIENCE

Results require minimal interpretation, allowing operators to concentrate on sample acquisition.

On-board computer automatically logs all data, including time, date, sample analysis and system status.

A comprehensive history of saved data and alarm files can be recalled and printed.

COST EFFECTIVE

Automated internal calibration eliminates cost of purchasing & managing calibration traps.

Low power consumption reducing cost to operate.

Patented Regenerative dryer increases uptime and eliminates cost of dryer material replacements.

EASE OF USE

Non-radioactive ionization source removes shipping restrictions and licensing requirements.

Ability to create custom substance libraries.

Built-in printer for fast hard copy results or printing later.

Quick analysis & results (approximately 8 seconds).

On-board software keypad and help files.

Automated, push-button maintenance can be scheduled.

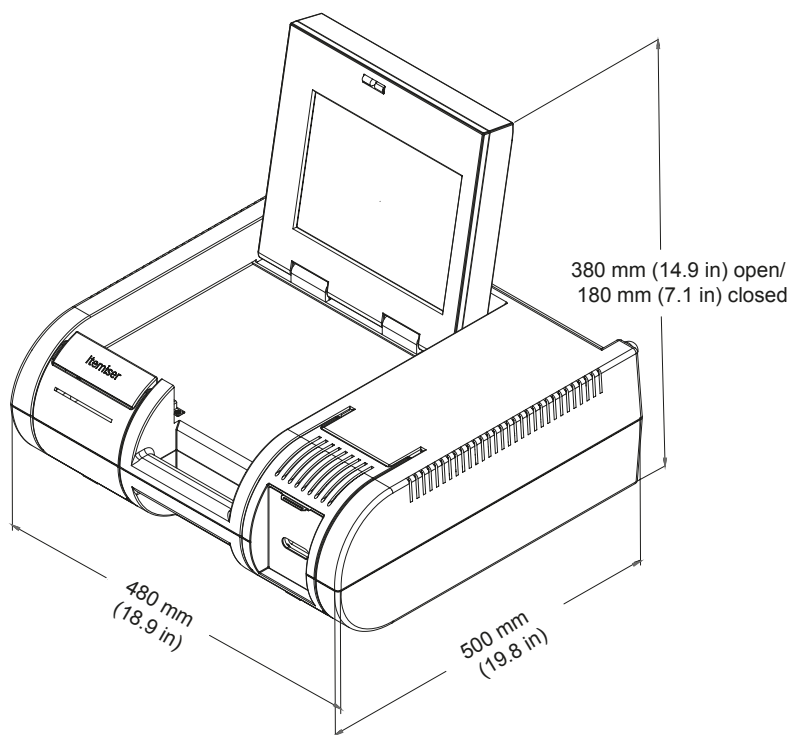

ENVIRONMENT & POWER

DETECTOR TYPE	Ion Trap Mobility Spectrometer (ITMS™)
ANALYSIS TIME	Default 8 seconds
SAMPLE ACQUISITION	Surface wipe (particulate)
OPERATING TEMP	0 to 40°C (32 to 104°F)
PROTECTION RATING	IP20
POWER	External AC to DC Power Supply Input 100-240 VAC, ~1.8 A, 47-63 Hz Output 15 VDC, 10 A, 150W
BATTERY BACKUP	Up to 60 minutes
SOLID STATE DRIVE	256 GB
OPERATING SYSTEM	Linux
DISPLAY	10.4 in (26.4 cm) LCD monitor with resistive touch screen
SIGNAL PROCESSING	Recognition on multiple peaks and explosives - Output to 4 different display types, including bar graph or time-of-flight plasmagram
DETECTION CAPABILITIES	Simultaneous detection of explosives and narcotics. Aviation certified configurations will be explosive only
DATA TRANSFER	Two USB 2.0 ports; Ethernet port

PHYSICAL SPECIFICATIONS

DIMENSIONS	L	500 mm (19.8 in) open 460 mm (18 in) closed
	W	480 mm (18.9 in)
NET WEIGHT (Approx)	H	380 mm (14.9 in) open 180 mm (7.1 in) closed
		12.99 Kg (28.65 lbs)

info@rapiscansystems.com

www.rapiscansystems.com



Rapiscan
systems
An OSI Systems Company

Rapiscan® Systems is ISO 9001:2015 Certified

The product images, specifications and information in this document are accurate as of the date of publication. This document summarizes key product features, but is not intended to constitute a comprehensive description of all specifications, benefits, shortcomings or risks associated with product use and operation. We disclaim any and all liability for any errors, inaccuracies or omissions and specifically disclaim any and all liabilities incurred as a consequence, direct or indirect, of any reliance upon the contents of this document. Actual product performance may vary and is dependent upon a number of factors, including factors that are outside of Rapiscan's control, including, but not limited to: (i) proper care, maintenance and repair, (ii) operating and storage environmental conditions, and (iii) system operator performance. Rapiscan makes no representation, warranty, or guaranty regarding the product, whether express or implied, including its suitability for any particular purpose or its performance under all conditions or circumstances. Due to applicable export laws and regulations, please note that the product may not be available for purchase in all locations globally or to all purchasers.

DS-ITEMISER5X-005



Thanks for Downloading

www.selmatec.no | sales@selmatec.no



Selmatec AS is an ISO9001: 2015 approved company and an Environmental Certified company (Miljøfyrtårn)

